

ca. 775

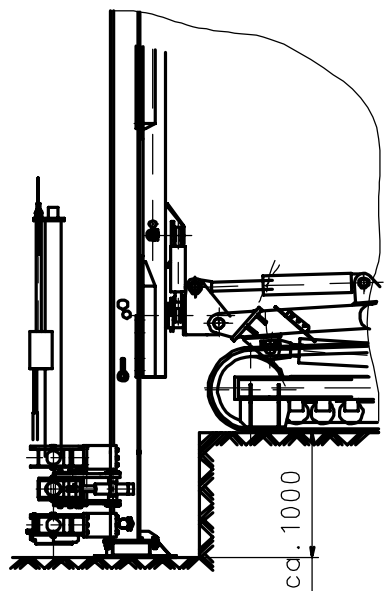

ca. 1000

Hydr. Drehantrieb KH9  
Hydr. rotary power KH9

Hydr. Drehantrieb KH27  
Hydr. rotary power KH27

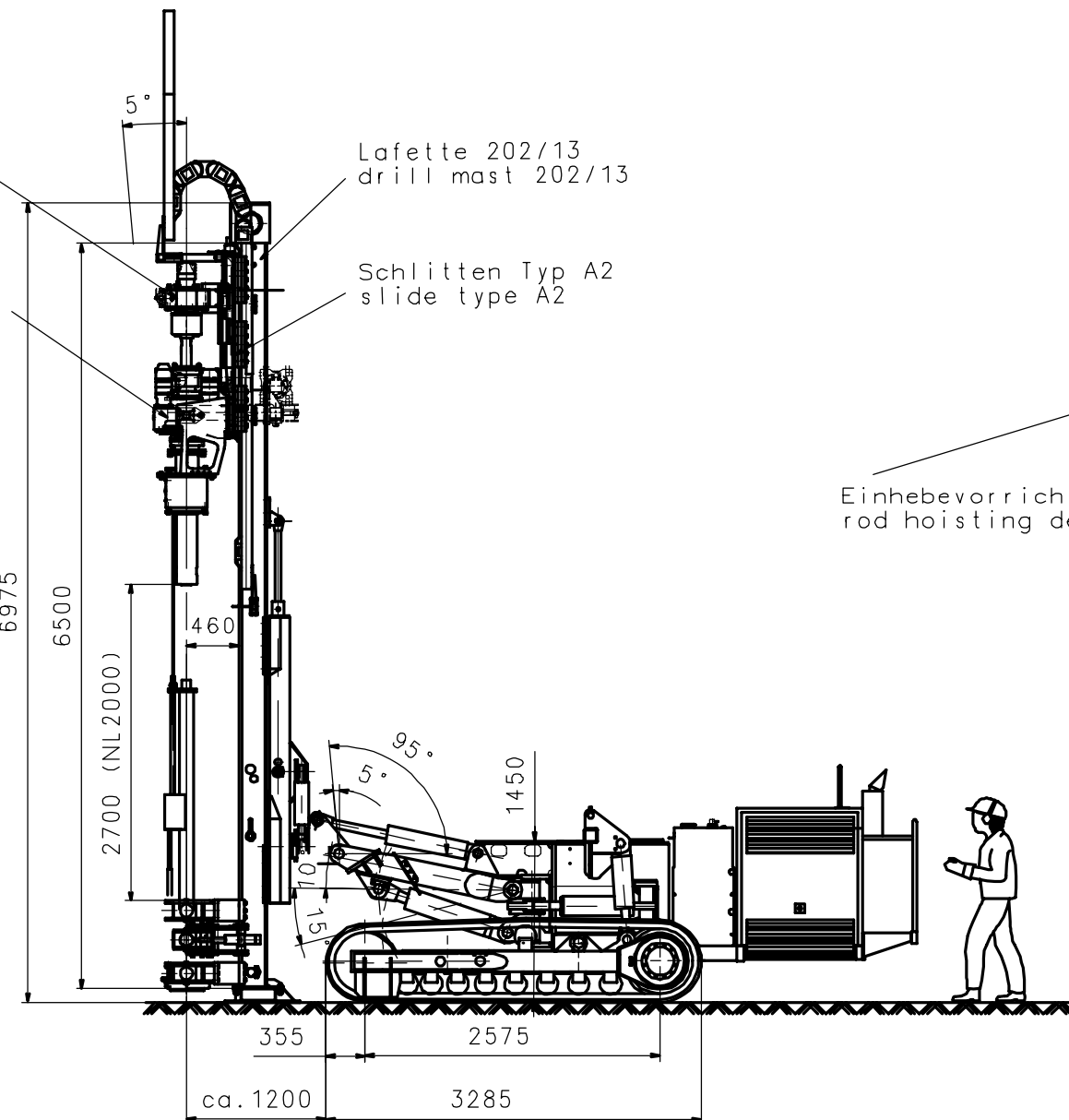

Lafette 202/13  
drill mast 202/13

Schlitten Typ A2  
slide type A2

Einhebevorrichtung  
rod hoisting device

6975

6500

2700 (NL2000)

460

95°

5°

1450

ca. 1200

355

2575

3285

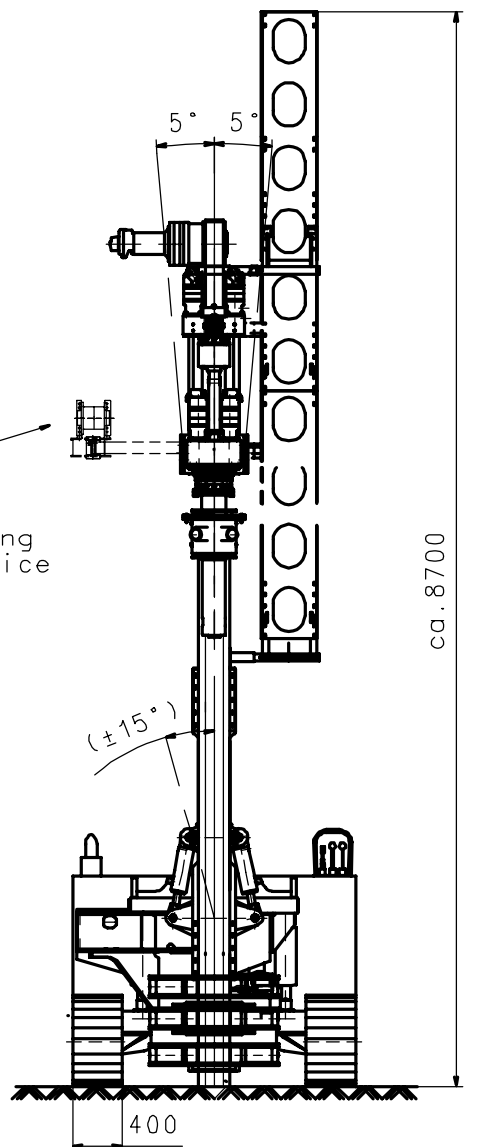

(±15°)

5° 5°

ca. 8700

400

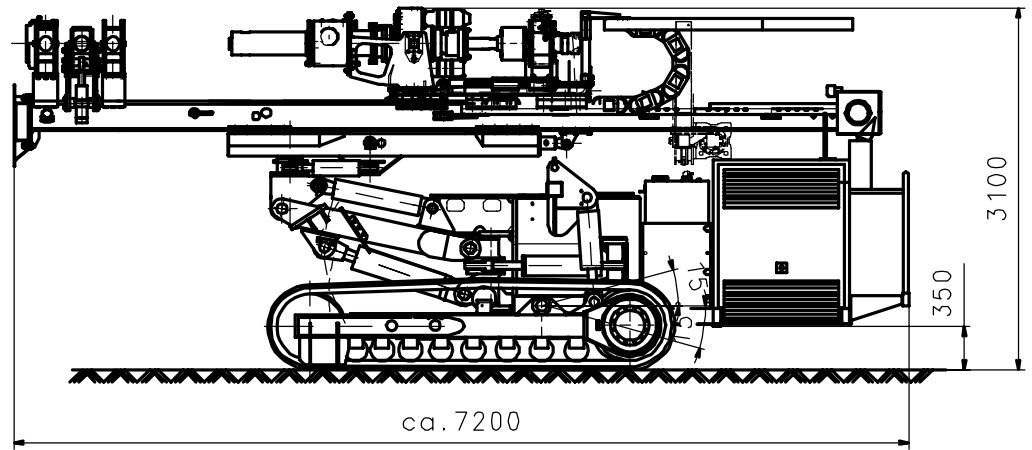

ca. 7200

3100

350

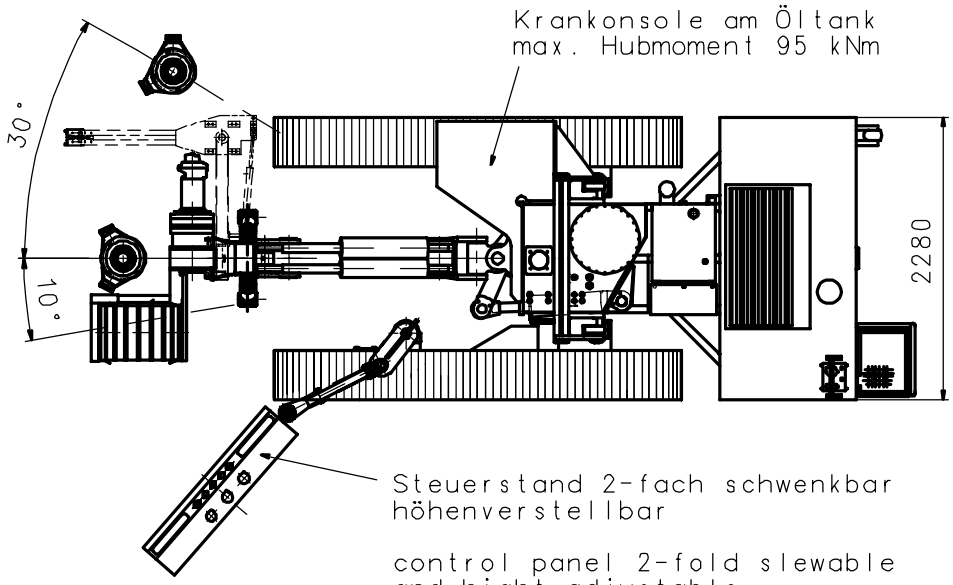

Krankkonsole am Öltank  
max. Hubmoment 95 kNm

30°

10°

2280

Steuerstand 2-fach schwenkbar  
höhenverstellbar

control panel 2-fold slewable  
and hight adjustable

Transportmaße (ohne Kran)  
transport dimensions (without crane)

Höhe (height)	ca. 3100mm
Breite (width)	ca. 2280mm
Länge (length)	ca. 7200mm
Gewicht (weight)	ca. 15.2t

2005	Datum	Name	KLEMM	Z-Nr. A500934-1
14 10	14 10	14 10		
1:25	Maßstab		Maßzeichnung	
M-52037			KR 805-1W	
Änderung			M-52037	